

# Gate Valve

Resilient Seated-300PSI-OS&Y Type-Groove-Groove Ends

Fig. 399GG.

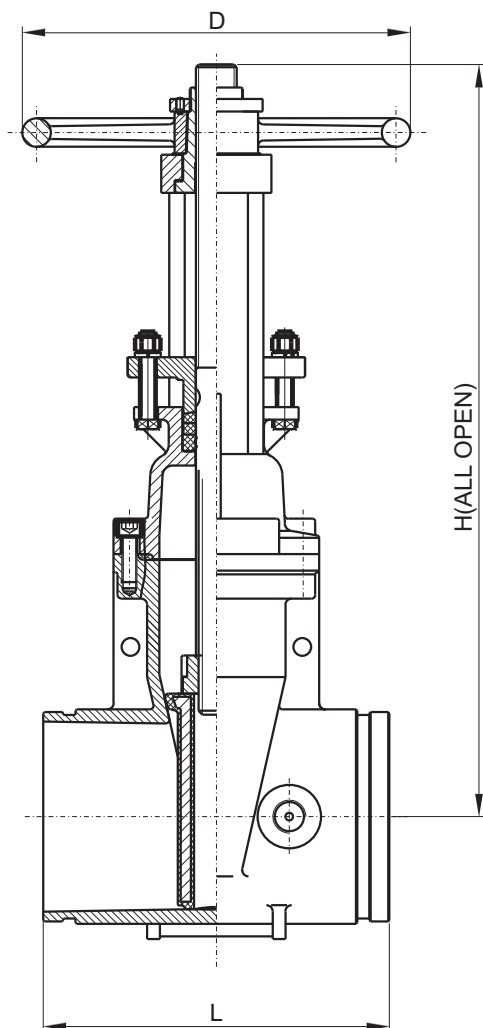

### Valve Standard

Conforms to AWWA C515 / BS5163

### Working pressure

21 Bar/300PSI

### Flanged Ends

AWWA C 606

### Materials List

Part Name	Material	Specification
Body	Ductile Iron	A536 65-45-12
Wedge	Ductile Iron EPDM Coated	
Wedge Nut	Stainless Steel	AISI304
Stem	Stainless Steel	AISI304/302
Bonnet	Ductile Iron	A536 65-45-12
Gasket	EPDM	Commercial
Packing	Graphite	Non-asbestos
Stem Nut	Bronze	ASTM B62
Handwheel	Ductile Iron	A536 65-45-12

### Dimensions(mm/inch):

SIZE	mm	50	65	80	100	125	150	200	250	300
	inch	2	2 <sup>1</sup> / <sub>2</sub>	3	4	5	6	8	10	12
L	mm	178	191	203	229	254	267	292	330	356
	inch	7.00	7.50	8.00	9.00	10.00	10.50	11.50	13.00	14.00
H	mm	418	418	488	538	654	740	935	1126	1316
	inch	16.46	16.46	19.21	21.18	25.75	29.13	36.81	44.33	51.81
D	mm	183	183	253	253	306	306	355	445	445
	inch	7.20	7.20	9.96	9.96	12.05	12.05	13.98	17.52	17.52

# CERTIFICATE OF COMPLIANCE

**Certificate Number** 20130703-EX16373  
**Report Reference** EX16373-20130701  
**Issue Date** 2013-JULY-03

**Issued to:** GALA RS INC  
SUITE 201, 11200 WESTHEIMER RD  
HOUSTON, TX, 77042, US

**This is to certify that  
representative samples of**

## Gate Valves

**Resilient Seated Gate Valves** - 388FF-300, 388GG-300, 388FG-300, 399FF-300, **399GG-300**, 399FG-300, 388FF-250, 388GG-250, 388FG-250, 399FF-250, 399GG-250, 399FG-250, 388FF-200, 388GG-200, 388FG-200, 399FF-200, 399GG-200, 399FG-200.

Have been investigated by UL in accordance with the Standard(s) indicated on this Certificate.

**Standard(s) for Safety:** Standard for Gate Valves for Fire-Protection Service - UL 262

**Additional Information:** See the UL Online Certifications Directory at [www.ul.com/database](http://www.ul.com/database) for additional information

Only those products bearing the UL Listing Mark should be considered as being covered by UL's Listing and Follow-Up Service.

The UL Listing Mark generally includes the following elements: the symbol UL in a circle:  with the word "LISTED"; a control number (may be alphanumeric) assigned by UL; and the product category name (product identifier) as indicated in the appropriate UL Directory.

Look for the UL Listing Mark on the product.



William R. Carney, Director, North American Certification Programs  
UL LLC

Any information and documentation involving UL Mark services are provided on behalf of UL LLC (UL) or any authorized licensee of UL. For questions, please contact a local UL Customer Service Representative at [www.ul.com/contactus](http://www.ul.com/contactus)





# Certificate of Compliance

This certificate is issued for the following:

**OUTSIDE SCREW & YOKE TYPE (OS&Y) GATE VALVE**

MODELS 399FF-300, 399FF-250, 399FF-200, **399GG-300**, 399GG-250, 399GG-200,  
399FG-300, 399FG-250, 399FG-200

**NON-RISING STEM TYPE (NRS) GATE VALVE**

MODELS 388FF-300, 388FF-250, 388FF-200, 388GG-300, 388GG-250, 388GG-200,  
388FG-300, 388FG-250, 388FG-200

**INDICATOR POST MODELS G388 AND W388**

**SWING CHECK VALVE MODELS 50FF-300, 50FF-250, 50FF-200**

**Prepared for:**

GALA RS Inc  
11200 Westheimer  
Suite 201  
Houston, TX 77042

FM Approvals Class: 1120/1130, 1110, 1210

Approval Identification: 0003049247

Approval Granted: July 12, 2013

To verify the availability of the Approved product, please refer to [www.approvalguide.com](http://www.approvalguide.com)

Said Approval is subject to satisfactory field performance, continuing Surveillance Audits, and strict conformity to the constructions as shown in the Approval Guide, an online resource of FM Approvals.

A handwritten signature in dark ink, appearing to read 'Richard B. Dunne', is written over a horizontal line.

Richard B. Dunne  
Group Manager -Fire Protection  
FM Approvals  
1151 Boston-Providence Turnpike  
Norwood, MA 02062

August 7, 2013  
Date



*Member of the FM Global Group*