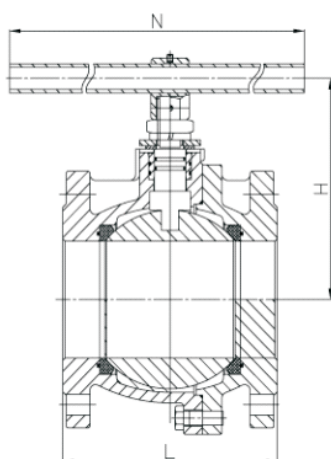

Fig. 4102



Valve Standard :

Comply with MSS SP-72
 Face-to-face Dimension Conforms to
 BS EN558-1 Series 14 (DIN 3202 F4) for DN50-DN100
 BS EN558-1 Series 15 (DIN 3202 F5) for DN125-DN200

Pressure Temperature Ratings

Working pressure	16bar
Testing Pressure	Shell:24bar
	Seal:17.6bar
Working Temperature	-10°C to 120°C

Flange Drilling Suited for :

ANSI 150

Material Specification

Part	Material	ASTM Spec.
Body	Cast Iron	EN-JL 1040
Bonnet	Cast Iron	EN-JL 1040
Ball	Stainless Steel 304	BS970 304S15
Seat	PTFE	Commercial
Shaft	Stainless Steel 420	BS970 420S37
Handle	Carbon Steel	Mild Steel

Dimensions

DN	mm	50	65	80	100	125	150	200
	inch	2	2-1/2	3	4	5	6	8
L		150	170	180	190	325	350	400
H		115	130	140	155	195	240	325
N		220	284	284	500	600	800	1000